

## Datasheet

### Mounting frame single

Part No: 100487, 100488

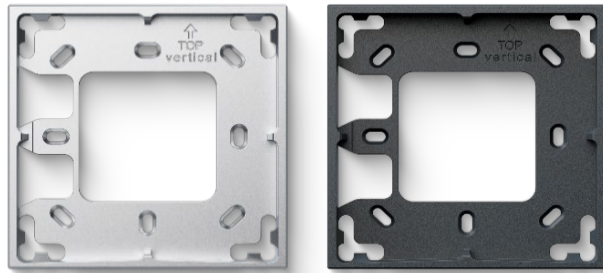

### About the product

The high-quality mounting frame made of anodized aluminum is perfect for mounting the Intercom, NFC Code Touch (Gen. 2) or Touch Pure on any facade.

### Product Characteristics

Material	Aluminium
Colours	Silver: RAL9003 - Part No. 100487 Anthracite: RAL7021 - Part No. 100488

### Dimensions & Weight

Net weight	35g
Total weight	45g
Product dimensions	90x90x11mm / 3.55x3.55x0.43" (LxWxH)

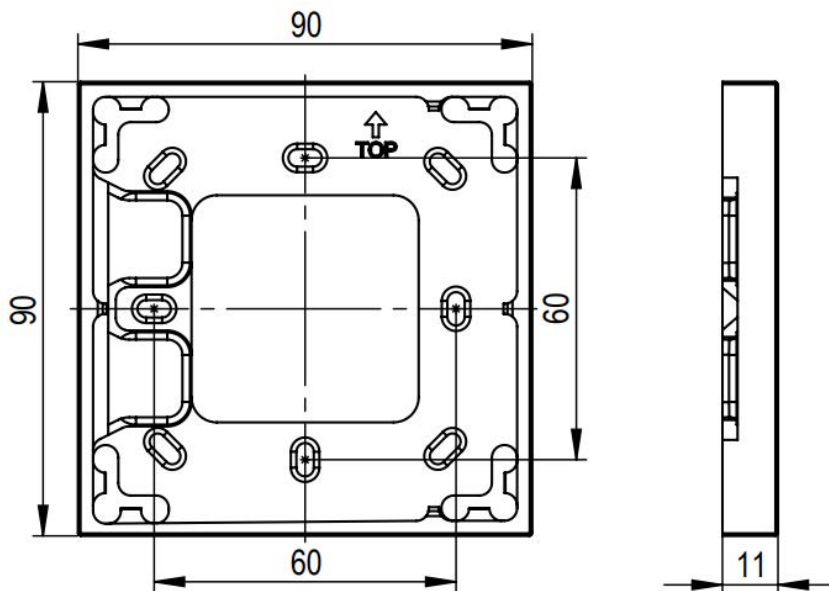

Pack size	104x107x39mm / 4.09x4.21x1.54" (LxWxH)
-----------	--

### Published by Loxone Electronics GmbH

Smart Home 1  
4154 Kollerschlag  
Austria  
Tel: +43 7287 7070-0  
loxone.com

## Datenblatt

### Montagerahmen 1fach

Art. Nr. 100487, 100488

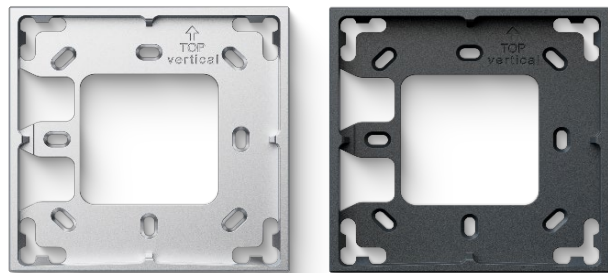

### Information zum Produkt

Der hochwertige Montagerahmen aus eloxiertem Aluminium eignet sich perfekt zur Befestigung der Intercom, des NFC Code Touchs (Gen. 2) oder des Touch Pures auf jeder Fassade.

### Produkteigenschaften

Material	Aluminium
Farbe	Silber: RAL9003 - Art. Nr. 100487 Anthrazit: RAL7021 - Art. Nr. 100488

### Abmessungen & Gewicht

Nettogewicht	35g
Bruttogewicht	45g
Produktmaße	90x90x11mm / 3,55x3,55x0,43" (LxBxH)

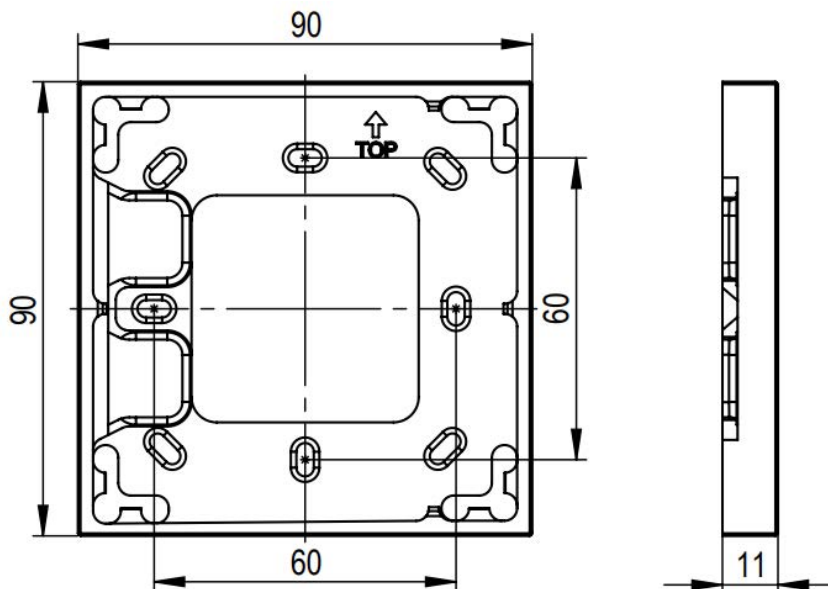

Packmaß	104x107x39mm / 4,09x4,21x1,54" (LxBxH)
---------	--

### Veröffentlicht von

#### Loxone Electronics GmbH

Smart Home 1  
4154 Kollerschlag  
Austria  
Tel: +43 7287 7070-0  
loxone.com